

1/20W, 0201, Thick Film Embedded Resistor (Halogen Free)

Reversion History :

Date	Revision	Changes
2014.09.22	A0	New Approval
2015.05.27	A1	/
2019.09.17	A2	New Version
2020.08.06	A3	Modified title, added application description
2021.01.11	A4	Modify lead free related description
2021.03.02	A5	Fix some of p5 Endurance mistakes

1/20W, 0201, Thick Film Embedded Resistor (Halogen Free)

Features / Applications :

- Copper electrode
- Telecommunication Equipment, Digital Cameras
Watches, Pocket Calculators, Computers, Instruments
- Applied to embedded process
- Halogen Free Epoxy
- RoHS compliant
 - Glass/electrode of resistor with lead free meet RoHS requirements
 - Pb contained in resistive element is exempted by RoHS



Electrical Specifications :

Power Rating*	Resistance Values Series	Resistance Tolerance	Resistance Range (Ω)	Temperature Coefficient of Resistance ppm /°C (Code)	Operating Temperature Range	Max. Operating Voltage
1/20W	E24 series E96 series	±1%(F)	10 ~ 91	± 300	-55°C to 125°C	25V
			100 ~ 1M	± 200		
	E24 series	±2%(G) ±5%(J)	10 ~ 91	± 300		
			100 ~ 1M	± 200		
Jumper	Resistance		Rated current		Operating Temperature Range	
	Below 50mΩ		1A		-55°C to 125°C	

Note: *Package Power Temperature Derating Curve

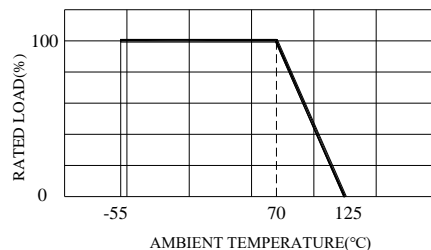

Figure 1. : Power Temperature Derating Curve

Note: **Resistors shall have a rated DC or AC(rms.) continuous operating voltage corresponding to the power rating, as calculated from the following formula

$$V = \sqrt{P \times R}$$

Where V : Rated voltage (V)

P : Rated power (W)

R : Nominal resistance (Ω)

If the voltage so obtained exceeds the maximum operating voltage, this maximum voltage shall be the rated voltage.

Outline Drawing :

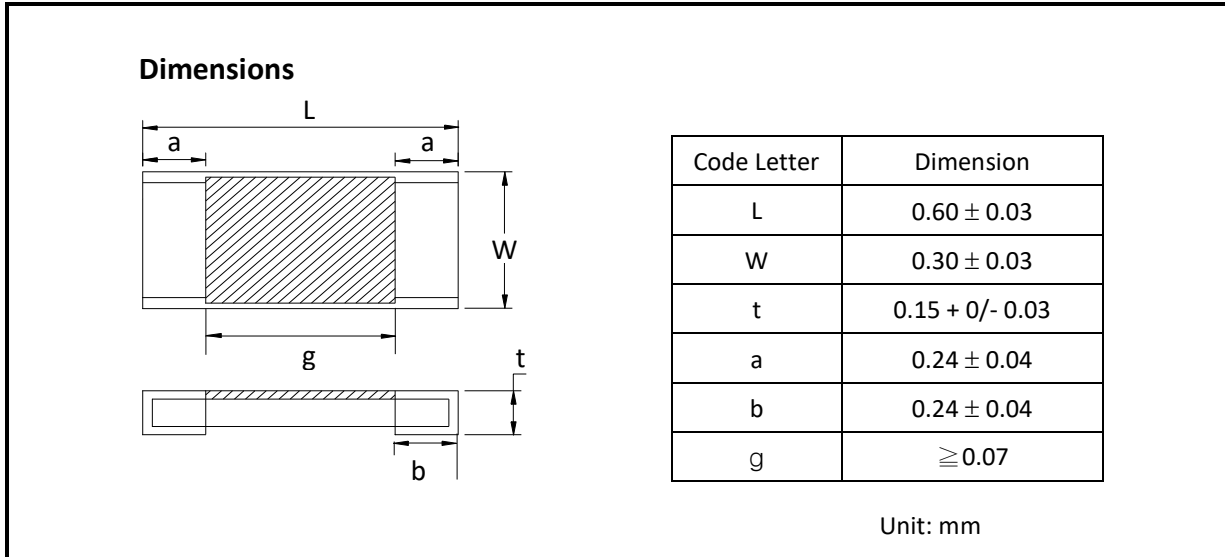

Type Designation :

RR0306SE - XXXX - X D - NH

(1) (2) (3) (4) (5)

Note :

- (1) Series No.
- (2) Resistance value : 103 = $10k\Omega$ (E24) ; 1131 = $1.13k\Omega$ (E96)
- (3) Tolerance : F = $\pm 1\%$, G = $\pm 2\%$, J = $\pm 5\%$, X = Jumper (Below $50m\Omega$)
- (4) D = $1/20W$
- (5) Electrode component: Lead free and No Halogen, RoHS compliant

Characteristics :

Electrical

Item	Specification and Requirement		Test Method
	Resistor	Jumper	
Short Time Overload	$\Delta R: \pm (2\% + 0.1)\Omega$ Without damage by flashover, spark, arcing, burning or breakdown	Max. 50m Ω	(1) Applied voltage: 2.5 x rated voltage or 2 x maximum operating voltage which ever is less (2) Test time : 5 seconds
Insulation Resistance	Over 100 M Ω on Overcoat layer face up Over 1,000 M Ω on Substrate side face up		(1) Setup as figure 1 (2) Test voltage: 100 V _{DC} (3) Test time: 60 + 10 / -0 seconds
Voltage Proof	$\Delta R: \pm (2\% + 0.1)\Omega$ Without damage by flashover, spark, arcing, burning or breakdown	Max. 50m Ω	(1) Setup as figure 1 (2) Test voltage: 100 V _{AC(rms.)} (3) Test time: 60 +10 / -0 seconds

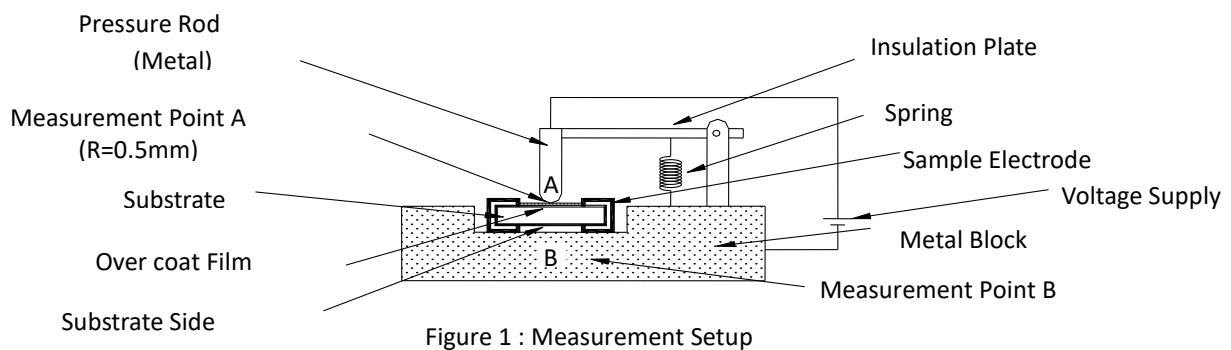

Mechanical

Item	Specification and Requirement		Test Method
	Resistor	Jumper	
Bending Test	$\Delta R: \pm (1.0\% + 0.05)\Omega$ Without mechanical damage such as break		Bending value: 2 mm for 30 ± 1 seconds
Solvent Resistance	Marking should be legible Without mechanical and distinct damage in appearance	Max. $50m\Omega$	(1) Solvent: Trichloroethane or Isopropyl alcohol (2) Immersed in solvent at room temperature for 90 seconds

Endurance

Item	Specification and Requirement		Test Method
	Jumper	Jumper	
Rapid change of Temperature	$\Delta R: \pm(1.0\% + 0.05\Omega)$ Without distinct damage in appearance	Max. 50m Ω	(1) Repeat 5 cycle as follow: (-55 \pm 3 $^{\circ}$ C,30minutes) \rightarrow (Room temperature, 2~3 minutes) \rightarrow (+125 \pm 2 $^{\circ}$ C,30minutes) \rightarrow (Room temperature, 2~3 minutes) (2) Measuring resistance 1 hour after test
Moisture with Load	$\Delta R: \pm(5.0\% + 0.1\Omega)$ Without distinct damage in appearance Marking should be legible	Max. 50m Ω	(1) Environment condition: 40 \pm 2 $^{\circ}$ C,90~95% RH (2) Applied Voltage: rated voltage (3) Test period: (1.5 hour ON) \rightarrow (0.5 hour OFF) cycled for total 1,000 + 48 / - 0 hours (4) Measuring resistance 1 hour after test
Load Life	$\Delta R: \pm(5.0\% + 0.1\Omega)$ Without distinct damage in appearance	Max. 100m Ω	(1) Test temperature: 70 \pm 2 $^{\circ}$ C (2) Applied Voltage: rated Voltage (3) Test period: (1.5 hour ON) \rightarrow (0.5 hour OFF) cycled for total 1,000 + 48 / - 0 hours (4) Measuring resistance 1 hour after test
Low Temperature Store	$\Delta R: \pm(5.0\% + 0.1\Omega)$ Without distinct damage in appearance	Max. 100m Ω	(1) Store temperature: -55 \pm 3 $^{\circ}$ C for total 1,000 + 48 / - 0 hours (2) Measuring resistance 1 hour after test
High Temperature Store	$\Delta R: \pm(5.0\% + 0.1\Omega)$ Without distinct damage in appearance	Max. 100m Ω	(1) Store temperature: +125 \pm 2 $^{\circ}$ C for total 1,000 + 48 / - 0 hours (2) Measuring resistance 1 hour after test

TAPE PACKAGING DIMENSIONS:

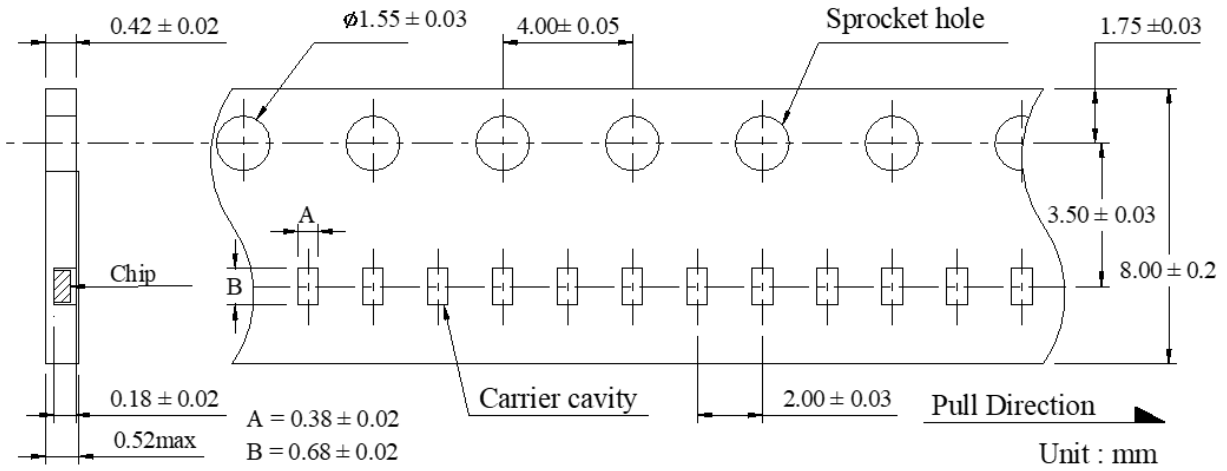

REEL DIMENSIONS:

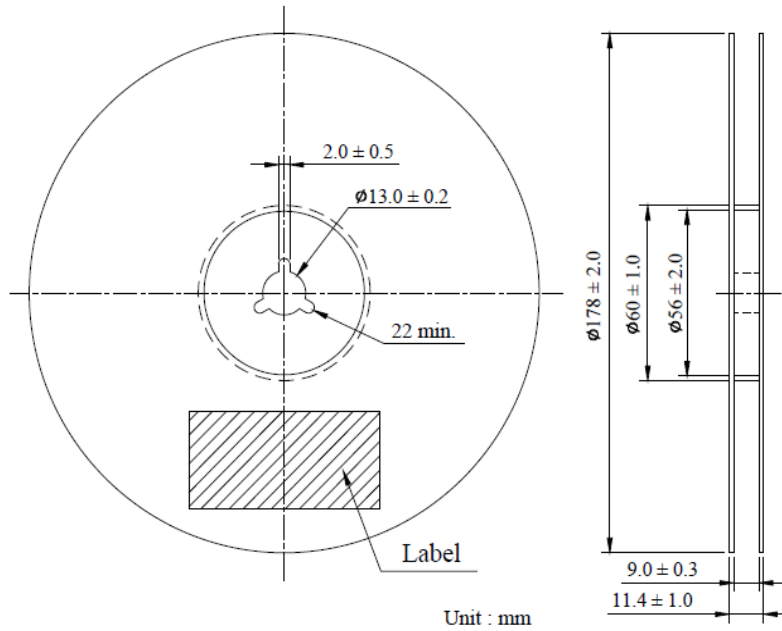

Numbers of Taping: 10,000 pieces/reel

The following items shall be marked on the reel.

- (1) Type designation.
- (2) Quantity
- (3) Manufacturing date code
- (4) Manufacturer's name

Peel force of top cover tape

The peel speed shall be about 300 mm/min. The peel force of top cover tape shall be between 0.1 to 0.7 N.

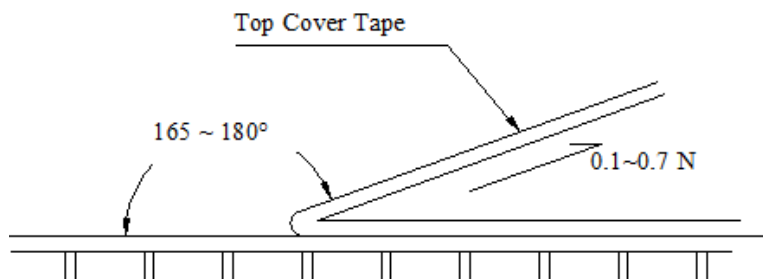

Care Note :

Care note for storage

- (1) Chip resistor shall be stored in a room where temperature and humidity must be controlled.
(temperature 5 to 35°C, humidity 45 to 85% RH) However, a humidity keep it low, as it is possible.
- (2) Chip resistor shall be stored as direct sunshine doesn't hit on it.
- (3) Chip resistor shall be stored with no moisture, dust, a material that will make solder ability inferior, and a harmful gas (Hydrogen chloride, sulfurous acid gas, and Hydrogen sulfide)

Care note for operating and handling

- (1) It is necessary to protect the edge and protection coat of resistors from mechanical stress.
- (2) Handle with care when printing circuit board (PCB) is divided or fixed on support body, because bending of printing circuit board (PCB) mounting will make mechanical stress for resistors.
- (3) Resistors shall be used with in rated range shown in specification. Especially, if voltage more than specified value will be loaded to resistor, there is a case it will make damage for machine because of temperature rise depending on generating of heat, and increase resistance value or breaks.
- (4) In case that resistor is loaded a rated voltage, it is necessary to confirms temperature of a resistor and to reduce a load power according to load reduction curve, because a temperature rise of a resistor depends on influence of heat from mounting density and neighboring element.
- (5) Observe Limiting element voltage and maximum overload voltage specified in each specification.
- (6) If there is possibility that a large voltage (pulse voltage, shock voltage) charge to resistor, it is necessary that operating condition shall be set up before use.